

UNDERWATER BRITESTREAM LED LIGHT MK4

Fibreglass Pools
Vinyl Liner Pools
Concrete Walled Pools



⚠ WARNING

This equipment must be installed and serviced by a qualified technician. Improper installation can create electrical hazards which could result in property damage, serious injury or death. Improper installation will void the warranty.



Notice to Installer

This manual contains important information about the installation, operation and safe use of this product. Once the product has been installed **this manual must be given to the owner/ operator of this equipment.**

CAUTION

- *Submerge the light in the water before switching it on, to avoid over heating.*
- *Wind sufficient cable behind light to allow for removal from the pool for servicing.*
- *Light must be installed not more than 600mm below top of coping, to allow for removal from pool for servicing.*
- *Surrounding area has to be clear and unencumbered to allow for adequate space to service the light.*
- *Cutting an underwater section of cable will void the warranty unless done so in conjunction with the Underwater Light Replacement Kit.*

INSTALLATION CONCRETE WALLED POOLS

- Set conduit for light power cord as normal at 550mm below top of coping.
- Render or marble sheen Wall Ring in wall. Make sure the word "Top" is up.
- Attach under water light Twist Lock Adaptor to Wall Ring with screws.
- Wind power cord loosely around back of light. Ensure it is properly retained within securing clips.

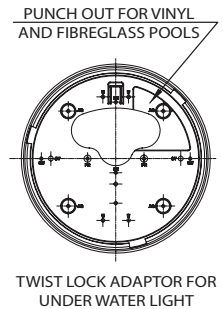
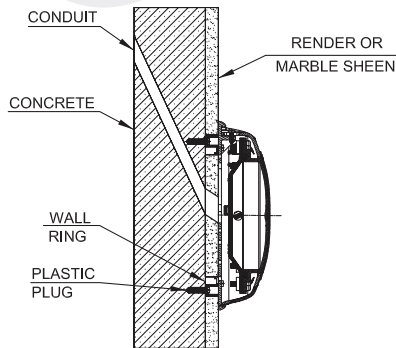

Figure 1

- Feed remaining power cord through conduit.
- Fit the light to the under water Twist Lock Adaptor by aligning the lights locking lugs with the locking slots in the Twist Lock Adaptor. Turn the Twist Lock Adaptor clockwise fully into the locked position. Fix light to Twist Lock Adaptor with screw at the top to prevent unlocking.

INSTALLATION VINYL LINER POOLS

- Drill a 32mm hole in the pool wall (Vinyl / fibreglass conversion kit # 26601 required) at 550mm below top of coping. This is where the cable will pass through the wall. See figure 2.
- Mark fixing holes for Gland Plate and Wall Brackets. Drill holes to suit screws supplied.
- After fitting liner, slit liner at 32mm hole position. Fit Gland Plate and Wall Bracket.
- Wind cord loosely around back of light catching it in clips.
- Insert gland nut, rubber washer and then plastic seal ring onto the power cord and feed the power cord through the gland plate.
- Tighten gland nut onto gland plate.
- Fit light to Wall Bracket by sliding the light downwards until the clip and hook engage. Fix with screw at top.

INSTALLATION FIBREGLASS POOLS

- a) Drill a 28mm hole in the pool wall (Vinyl / fibreglass conversion kit # 26601 required) at 550mm below top of coping. This is where the cable will pass through the wall.
- b) Cover the back of the Gland Plate with Silicone Sealant and insert the boss of the Gland Plate into the drilled hole.
- c) Drill 4 holes with a 1/8" drill using the gland plate holes as a drilling guide. Apply a small amount of Silicone Sealant on the screws and drive into predrilled holes.
- d) Screw wall bracket to the wall and seal screws.
- e) Wind cord loosely around back of light catching it in clips.
- f) Insert gland nut, rubber washer and then plastic seal ring onto the power cord and feed the power cord through the gland plate.
- g) Tighten gland nut onto gland plate.
- h) Fit light to Wall Bracket by sliding the light downwards until the clip and hook engage. Fix with screw at top.

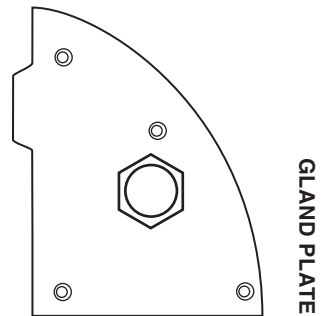

Figure 2

FAULT	POSSIBLE CAUSE	REMEDY
Light not operating	<ul style="list-style-type: none"> - Fuse in transformer blown. - No power to transformer. - Fault in electrical wiring. 	<ul style="list-style-type: none"> - Replace fuse. - Check main fuses in switchboard. - Electrician to check.
Light very dim and pulsating	<ul style="list-style-type: none"> - Mismatch of lamp and transformer ratings. - Damaged wiring/ connectors. 	<ul style="list-style-type: none"> - Fit correctly rated transformer*. - Replace wiring/ connectors.
Main house fuse blows when light switched on	<ul style="list-style-type: none"> - Faulty transformer - Damaged cable - Incorrect electrical installation. 	<ul style="list-style-type: none"> - Call electrician to check installation.

* Not to be used with switch mode or electronic transformers
Transformers recommended by Waterco for use with Britestream LED light

- Part No. 26505 - UWL Transformer 12Vac 100VA - for multiple lights (maximum 5 lights)
- Part No. 26503 - UWL Transformer 12Vac 42VA - for two lights

OFFICES - AUSTRALIA

NSW - SYDNEY
(HEAD OFFICE)
Tel: +61 2 9898 8600

QLD - BRISBANE
Tel: +61 7 3299 9900

VIC/TAS - MELBOURNE
Tel: +61 3 9764 1211

WA - PERTH
Tel: +61 8 9273 1900

SA/NT - ADELAIDE
Tel: +61 8 8244 6000

ACT DISTRIBUTION
Tel: +61 2 6280 6476

OFFICES - OVERSEAS

WATERCO (EUROPE) LIMITED
Sittingbourne, Kent, UK
Tel: +44 (0) 1795 521 733

WATERCO FRANCE
Saint Priest, France
Tel: +33 4 72 79 33 30

WATERCO (USA) INC
Augusta, Georgia, USA
Tel: +1 706 793 7291

WATERCO CANADA
Longueuil, Quebec, Canada
Tel: +1 450 748 1421

WATERCO (NZ) LIMITED
Auckland, New Zealand
Tel: +64 9 525 7570

WATERCO © LIMITED
Guangzhou, China
Tel: +86 20 3222 2180

WATERCO (FAR EAST) SDN BHD
Selangor, Malaysia
Tel: +60 3 6145 6000

PT WATERCO INDONESIA
Jakarta, Indonesia
Tel: +62 21 4585 1481

WATERCO SINGAPORE INTL PTE LTD
Nehsons Building, Singapore
Tel: +65 6344 2378

WATERCO

Waterco Limited ABN 62 002 070 733

