

Supastream Pool & Spa Pumps

State-of-the-art power



Supastream pumps are general purpose units designed for use in swimming pools and low pressure water re-circulation applications e.g. aquaculture, ponds and irrigation.



WATERCO
Water, the liquid of life

www.waterco.com

Supastream Pool and Spa Pumps

Efficient Impeller and Diffuser Design

The pump's impeller and diffuser design maximizes the hydraulic output of the pump while minimizing turbulence. The pump's efficient hydraulic performance shortens run times and reduces energy consumption leading to lower operating costs.

Engineered Durability

The pump body is manufactured utilizing state of the art engineering plastic molding with a single piece strainer pot and volute for extra strength. A high grade 316 stainless steel mechanical seal is incorporated for extra protection against corrosion e.g. from chlorinated water, ozone, iodine, Baquacil, bromine and salt water.

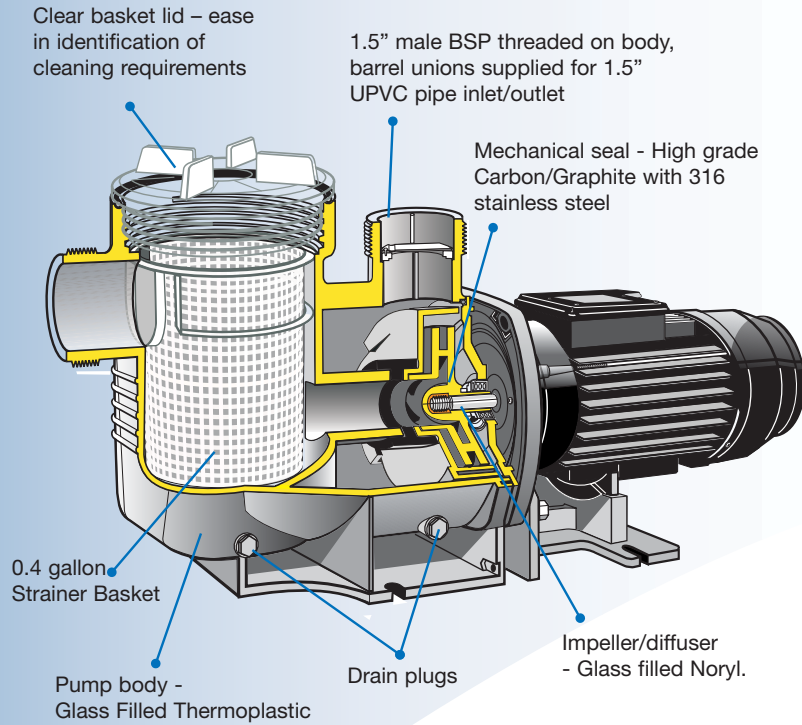

Motor:

- Motor shaft 303 grade stainless steel.
- Fan cooled.
- Thermal overload
- Picture shows IP55 style motor

| Product Description | Part No. | Carton Qty |
|---------------------|----------|------------|
| Supastream 0.75hp | 2403075 | 1 |
| Supastream 1.0hp | 2403100 | 1 |
| Supastream 1.5hp | 2403150 | 1 |
| Supastream 2.0hp | 2403200 | 1 |

| Model | Nom. HP | Total Length | Volts | Cycle | RPM |
|---------|---------|--------------|---------|-------|------|
| 2403075 | 0.75 | 21.5" | 110/220 | 60HZ | 3450 |
| 2403100 | 1.00 | 22.0" | 110/220 | 60HZ | 3450 |
| 2403150 | 1.50 | 22.5" | 110/220 | 60HZ | 3450 |
| 2403200 | 2.00 | 23.25" | 110/220 | 60HZ | 3450 |

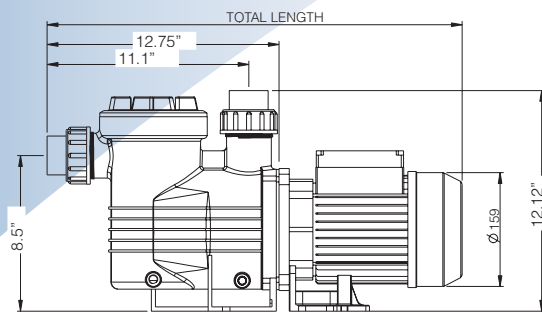

Supastream pump performance chart

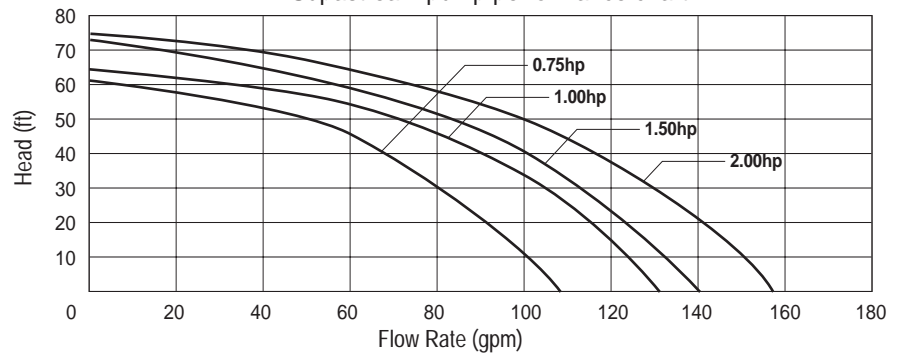

Warranty

Waterco pumps are covered by a comprehensive 2 year Warranty (1 year on mechanical seal) for residential installations and a 1 year Warranty for commercial installations.

WATERCO
Water, the liquid of life

WATERCO HEAD OFFICE
Sydney AUSTRALIA
Tel: +61 2 9898 8600

WATERCO USA
Waterco (USA) Inc
Phoenix, Arizona, USA
Tel: +1 623 434 4703
Waterco USA (Baker Hydro)
Augusta, USA
Tel: +1 706 793 7291

OFFICES - OVERSEAS

Waterco Canada (Focus Temp)
Quebec, Canada
Tel: +1 450 796 4333
Waterco (Europe) Limited
Radfield, Kent, UK
Tel: +44 (0) 1795 521 733
Waterco (NZ) Limited
Auckland, New Zealand
Tel: +64 9 525 7570

Waterco (GZ) Limited
Guangzhou, China
Tel: +86 20 3222 2180
Waterco (Far East) Sdn. Bhd.
Kuala Lumpur, Malaysia
Tel: +60 3 6145 6000
PT Waterco Indonesia
Jakarta, Indonesia
Tel: +62 21 4585 1481

DISTRIBUTED BY:



ZZU0914 03/06

In the interest of providing better quality and value we are constantly improving and updating our products. Consequently, pictures and information on our brochures may sometimes vary slightly from models available.